

# CC400 RF Transceiver

The CC400 is a high performance, single-chip FSK RF transceiver mainly intended for the 315 MHz and 433 MHz ISM/SRD bands. Its high receiver sensitivity (-112 dBm) and superior output power (+14 dBm) enable a very long communication range.

## A high performance RF solution

Very few, if any, single-chip RF transceivers offer radio parameters comparable to the CC400. With uncompromised focus on receiver sensitivity, output power and flexibility, the CC400 is designed for use in applications with the most stringent requirements. The transmitter, receiver, oscillator and control interface are totally integrated in a single-chip solution. Only a crystal and a few external passive components are required to build a high-performance and cost-effective radio system.

A communication range exceeding 2000 m can be reached with 10 dBm output power. The CC400 has a programmable carrier frequency and can be used at any frequency between 300 MHz and 500 MHz. The built-in, active power-down modes combined with a standby current as low as 0.2  $\mu$ A significantly extend battery life.

## Great flexibility and communication security

Virtually all radio parameters of the CC400 are programmable. The carrier frequency, frequency deviation, intermediate frequency, output power and much more can be easily programmed through a three-bit serial interface. The flexibility of the CC400 makes it ideal for a wide variety of applications. The Frequency Hopping Spread Spectrum (FHSS) option, together with other features that improve communication security, makes the CC400



especially suited for critical applications such as wireless alarms and security systems.

## All you need to get started..... and finished

The CC400 Development Kit makes it very easy to evaluate the performance of the CC400 chip, and in a short time, designers can develop their own RF modules based on this reference design. The SmartRF<sup>®</sup> Studio software package which is included, provides the flexibility needed to automatically generate configuration data used by the microcontroller.

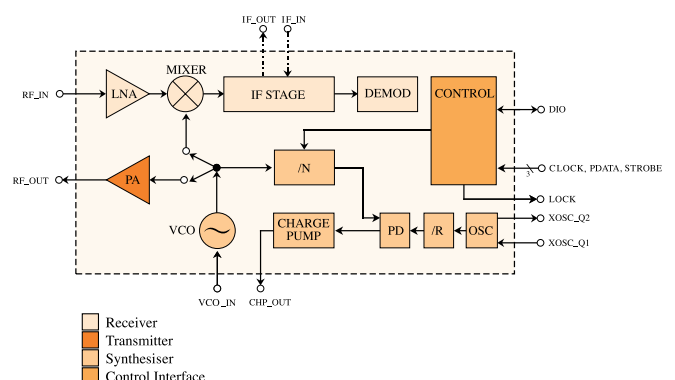

Block diagram CC400

Based on Chipcon's proprietary SmartRF® technology, the Chipcon RF-ICs offer the market's most competitive solutions to meet the stringent demands of today's wireless communication.

# CC400

SmartRF® - Connecting Smarter

## CC400 Features

- Single-chip RF transceiver
- Programmable frequency (300-500 MHz)
- Few external components required
- FSK modulation
- Low supply voltage (2.7 – 3.3 V)
- Very high receiver sensitivity (-112 dBm)
- Programmable output power ranging from -5 to 14 dBm
- Programmable frequency in 250 Hz steps
- Crystal temperature drift compensation possible without use of external TCXO
- Suitable for multi channel systems and frequency hopping protocols
- No external RF switch or IF filter required
- Single-port antenna connection
- Suitable for both narrow- and wide-band systems
- Small 28 pins SSOP package
- Complies with EN 300 220 and FCC CFR 47, part 15

## Applications

- Remote keyless entry
- Wireless alarm & security systems
- Home automation
- Automatic meter reading
- 315/433 MHz SRD band systems

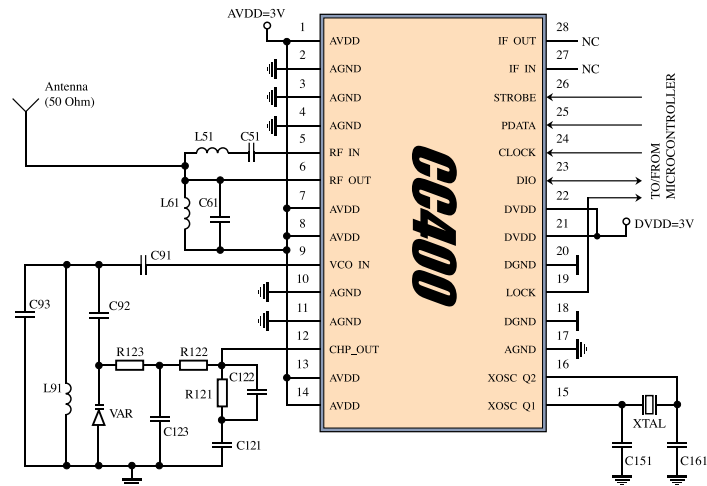

CC400 Application circuit: Very few external components required

| Specifications                       | Min                             | Typ (315 / 433 MHz) | Max | Unit   |    |
|--------------------------------------|---------------------------------|---------------------|-----|--------|----|
| General: RF Frequency Range          | 300                             |                     | 500 | MHz    |    |
| Data Rate                            | 0.3                             |                     | 9.6 | kbit/s |    |
| TX Mode: Output Power (programmable) | -5                              |                     | 14  | dBm    |    |
|                                      | FSK Separation (programmable)   | 1                   | 200 | kHz    |    |
| RX Mode: Receiver Sensitivity        |                                 | -112                |     | dBm    |    |
| Power Supply: Supply Voltage         | 2.7                             |                     | 3.3 | V      |    |
|                                      | Current Consumption, RX:        |                     | 18  | mA     |    |
|                                      | Current Consumption, TX, 0 dBm  |                     | 29  | mA     |    |
|                                      | Current Consumption, TX, 10 dBm |                     | 50  | mA     |    |
|                                      | Current Consumption, TX, 13 dBm |                     | 62  | mA     |    |
|                                      | Current Consumption, TX, 14 dBm |                     | 69  | mA     |    |
|                                      | Current Consumption, power down |                     | 0.2 | 1      | µA |



Chipcon AS, Gaustadalléen 21, NO-0349 Oslo, Norway. Tel: +47 22 95 85 44, fax: +47 22 95 85 46. E-mail: wireless@chipcon.com

[www.chipcon.com](http://www.chipcon.com)

[www.chipcon.com](http://www.chipcon.com)